

Type SGF/SGM Safety Guards

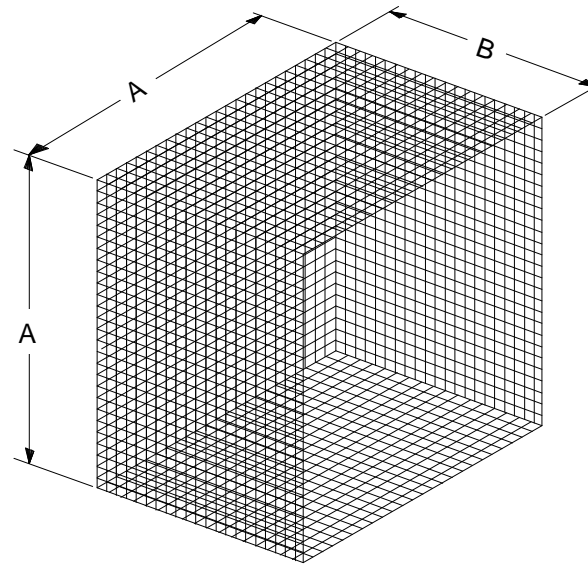

P.O. Box 2300 Jacksonville, Florida 32203
 Phone: (904) 389-3646
 Fax: (904) 387-3449 • (904) 381-7560
 E-mail: info@coolair.com
 Internet: www.coolair.com



Standard Features

- For use with American Coolair type UD and type C fans
- Basket type guard completely encloses all fan parts
- Meets OSHA regulations
- PVC coated steel wire
- Easily attached to fan panel
- Available for front (SGF) or motorside (SGM)

Fan Model	Fan Size	Motorside Type SGM Model No.	Dimensions in Inches		Front Type SGF Model No.	Dimensions in Inches	
			A	B		A	B
CDU - CDP - UDU - UDP ¹	7, 8	---	---	---	SGF7-8UDP	12	3 1/2
	10, 12	---	---	---	SGF10-12UDU/P	14	3 1/2
	14, 16	---	---	---	SGF14-16UDU/P	18	5 1/2
	18, 20	---	---	---	SGF18-20UDU/P	22	5 1/2
	24	---	---	---	SGF24UDU	28	5 1/2
CBA - CBL - CBH - CBHX - CBC - CDC - C-AL	18	SGM18	26	12	SGF18	22	5 1/2
	20	SGM20	26	12	SGF20	22	5 1/2
	24	SGM24	32	24	SGF24	29 ²	10
	30	SGM30	38	24	SGF30	35 ²	10
	36	SGM36	44	24	SGF36	41 ²	10
	42	SGM42	50	24	SGF42	47 ²	10
	48	SGM48	56	30	SGF48	53 ²	10
	54	SGM54	62	30	SGF54	59 ²	10
	60	SGM60	68	30	SGF60	65 ²	10
	72	SGM72BD	80	25	SGF72	77 ²	5
84	SGM84BD	92	25	SGF84	89 ²	5	

¹ - Motorside guard is standard on all CDP, CDU, UDU and UDP fans.

² - This dimension does not include 1" flange on all four sides.